

## ATTACHING THE MICRO FENCE TO YOUR ROUTER

The Micro Fence you ordered includes the appropriate mounting bar, pins and screws to fit the router you have specified. Once you have removed the fence from its packaging and checked all parts for tightness, simply slide the mounting pins into the existing holes in your router's base and install the screws we supply to lock the fence onto the router. (If your router already has the necessary locking screws, keep the set supplied with your Micro Fence for backup.)

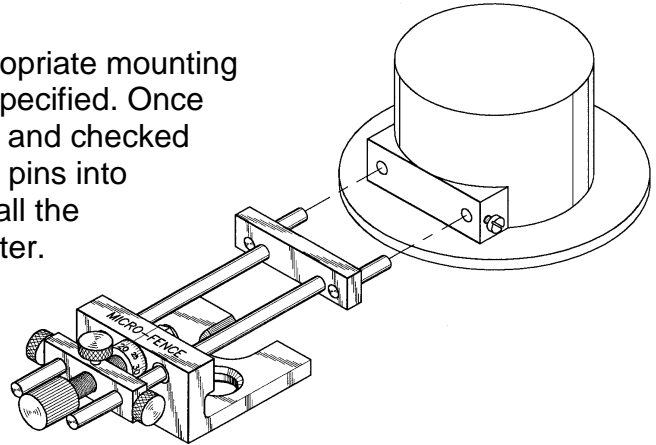

**Tip:** Care should be taken to check that all threaded joints are firmly tightened before using your edge guide. These include the mounting pins and guide shafts where they are threaded into the mounting bar, the screws holding the fence on the router, and the brass locking thumbscrews that position the fence and lock the spindle.

## BASIC MEASURING PROCEDURES

“Dial the Difference.”

The Micro Fence was designed to allow very accurate adjustments when using it in conjunction with a dial caliper. Both tools are calibrated in .001 increments. To set the router for any basic cut, use this simple **two-step** method:

**Tip:** Loosen the two brass locking thumbscrews (Fig. 1, #2), and preset the Micrometer Dial to 0.50 (it's the same as zero), before starting. This practice makes the arithmetic between cuts simple.

**Step 1:** Set the fence at a position that approximates the distance between the edge of the stock and the desired router bit cutting location. Make a test cut on a piece of scrap wood.

**Step 2:** Measure the distance between the edge of the work piece and the cut with your dial calipers.\* Calculate the difference between this measurement and the desired measurement (by simple subtraction), and then use the adjustment dial on the Micro Fence to reposition the fence relative to the bit by this amount.

**Example A:** Measuring the test cut shows an edge-to-bit distance of 1.133” inches. The desired distance is 1.250”, (a difference of .117”). The adjustment dial is used to move the fence .117” farther away from the bit.

\* The two most common measurements are 1.) the size of the cut itself and/or 2.) the distance the cut occurs from an edge or previous cut.

**Tip:** Turning the spindle clockwise draws the bit toward the fence; counter-clockwise pushes it away. Remember that routers rotate clockwise, (when viewed from above). Your feed should be counter-clockwise in most operations to avoid “climb cutting.” Take it easy. **NEVER force your router in any application.**

**Example B:** Here’s another way you can use Micro Fence’s precision adjustability to your advantage:

Lumber and plywood today aren’t usually precise in their dimension, (e.g., 3/4” plywood is frequently manufactured as much as 1/16” under-size). If it were full size, a 3/4” piece would measure .750”. In reality, however we frequently find goods that measure anywhere from .690 to .750. When a snug fit is crucial for joinery or aesthetic considerations, you can use the Micro Fence with an under-sized bit to create tight fitting joints.

Let’s say the plywood parts you wish to join measure .710” thick. Starting with a 5/8 in. diameter straight bit, rout a groove and measure its width (bits don’t always cut exactly the size they’re supposed to). If it measures .625” wide, adjust the dial on the Micro Fence to reposition the fence by .085” (subtract the actual cut dimension from the thickness of your material), then take second cut. The second pass will widen the groove to .710” to fit your plywood.

**Tip:** It’s always a good idea when cutting joinery to include a little clearance. When joining 3/4” plywood, for instance, we recommend routing grooves or dadoses .010 -.015 wider than the stock’s thickness (.720” - .725” for the example above). This makes joints easier to assemble and allows room for the wood to swell when glue is applied to the joint.

**Reading Calipers:**

This example reads .818”. Read the inch and/or 1/10 inch from the scale on the beam (.800”). Read the 1/100 and 1/1000 inch from the dial (.018”).

To set zero: Wipe the lower jaw faces clean and loosen the bezel locking screw (under the Dial). Close the two lower jaws and rotate the bezel until the needle points to zero. Re-tighten the bezel lock to secure the bezel ring in its new position.

Your calipers will measure inside, outside, depth and offset dimensions. It can also be used as a gauge by setting the beam locking screw at whatever dimension you wish to test.

